

MRS Series

High-Efficiency, Low-Noise Models

250mm-120mm



Materials

Frame : Die Cast Aluminum
 Blades : Resin
 Flammability Grade: V-O

Specifications

Model		Voltage V	Frequency Hz	Current A	Input Power W	Speed r/min	Max. Air Flow m³/min (m³/h)	Max. Static Pressure Pa	Noise Level dB (A)	Capacitor μ F
Electronic Alarm Type	Standard Type									
MRS25-DM	MRS25-D	Single-Phase200	50	0.4	85	2790	21 (1260)	290	58	4.5
		Single-Phase200	60	0.7	120	3220	24 (1440)	320	62	4.5
		Single-Phase220	50	0.4	95	2820	21 (1260)	310	58	4.5
		Single-Phase220	60	0.7	130	3260	24 (1440)	360	62	4.5
		Single-Phase230	50	0.5	100	2830	21 (1260)	320	58	4.5
		Single-Phase230	60	0.7	135	3290	24 (1440)	360	62	4.5
MRS25-BM	MRS25-B	Single-Phase100	50	0.8	80	2800	21 (1260)	290	58	16
		Single-Phase100	60	1.1	110	3220	24 (1440)	320	62	16
		Single-Phase110	60	1.1	120	3280	24 (1440)	340	62	16
		Single-Phase115	60	1.1	125	3300	24 (1440)	360	62	16

- Values for maximum air flow and maximum static pressure are measured by the double-chamber method.
- Noise level is measured in the A range, at a distance of 1m from the fan intake side.
- A thermal protector is installed. If the fan heats up, the thermal protector goes into operation and the fan stops. Once the fan temperature drops, it will automatically restart. Perform inspection work after turning off the power source.
- Fans bearing the CE mark should only be used with Class I equipment. When installing into the equipment, either earth the fan or ensure that there is no contact with bare hands. For protection, use the optional finger guard. Standards specifications are listed on page D-2.

Alarm Specifications

Alarm Activation Speed 1800±300r/min

When fan a speed drops below 1800±300r/min, the alarm output signal is output continuously at H level.

Since alarm circuits do not have delay functions, an external delay circuit is required to prevent speed detection when starting the fan or at other times when fan speed is below the alarm activation speed. The prevent time should be at least 10 seconds.

Alarm Circuit

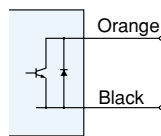

Orange Alarm Output(Open Collector)
 H (Tr=OFF):Abnormal Operation
 L (Tr=ON) :Normal Operation
 Black GND
 Maximum voltage:Vout =30V DC max.
 Maximum current:Iout =15mA max.

Air Flow – Static Pressure Characteristics

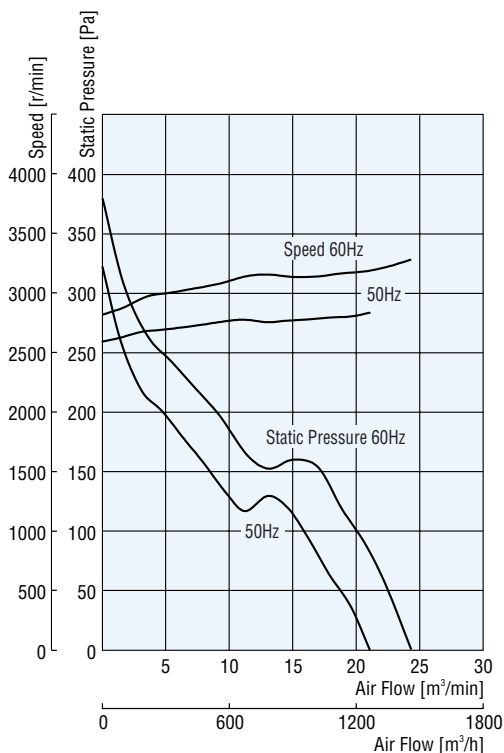

Audible Noise Frequency Analysis

Measured at a distance of 1m from the fan intake side

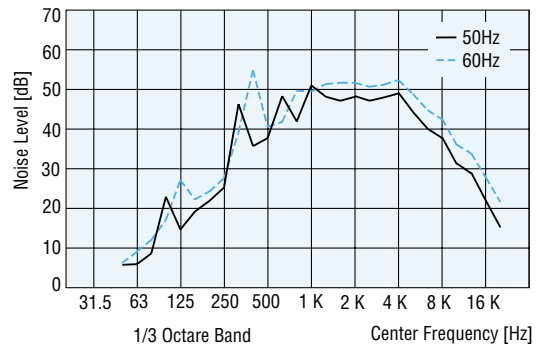

■ Dimensions (Scale 1/5, Unit=mm)

● Mass: 4.1kg

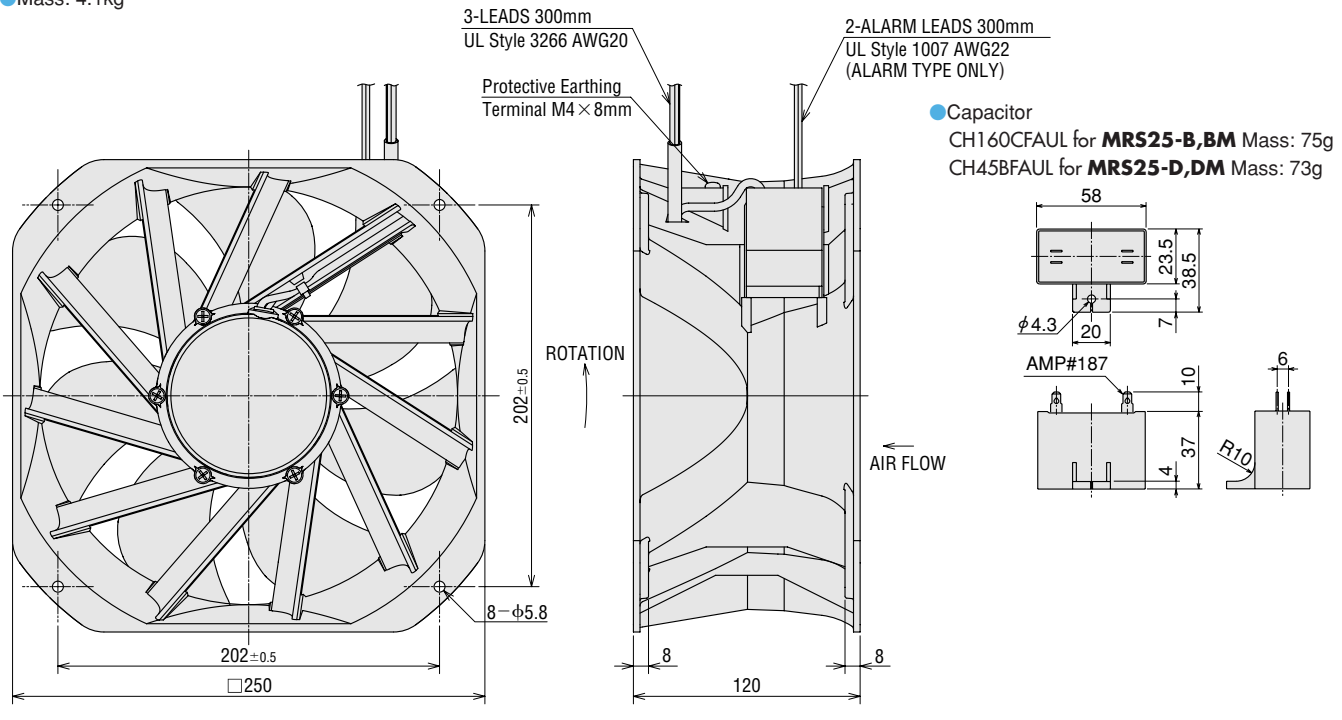

■ Panel Cut-Out (Scale 1/5, Unit: mm)

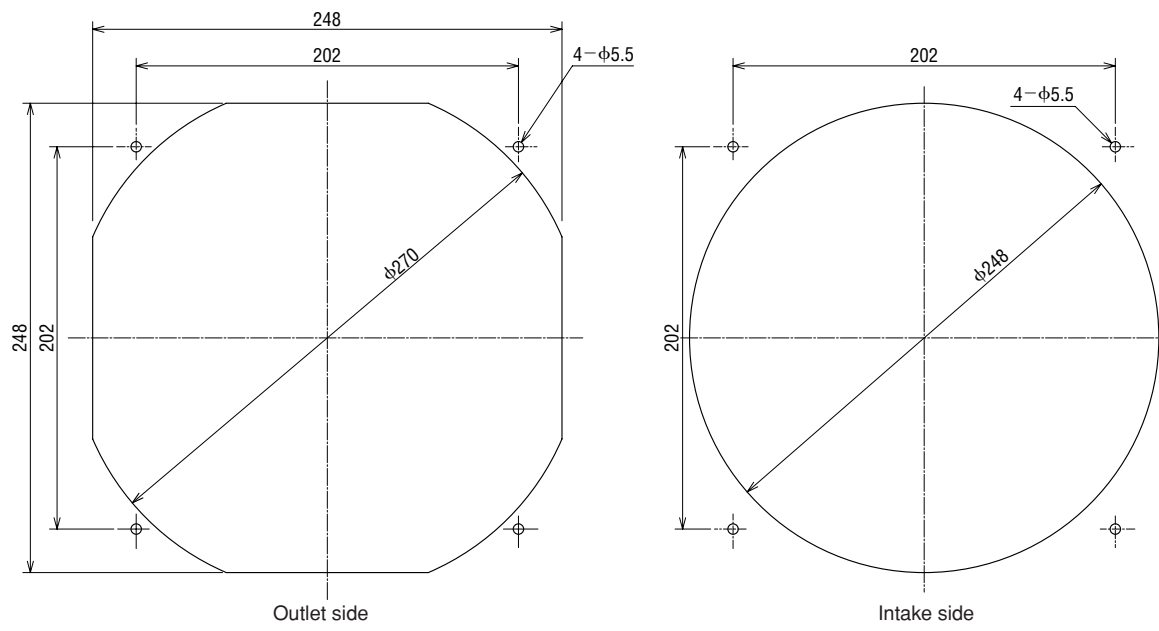

■ Wiring Diagrams

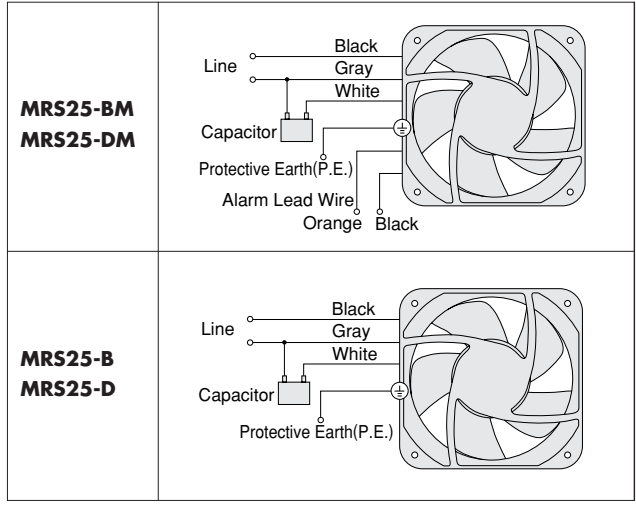

■ Accessories (Sold Separately)

Item	Model	Safety Standards	Page
Finger Guard	FG25D	*	C-99

* These products have been designed to pass tests set forth under the UL and CSA standards for equipment used in fans. They conform to the standards only when used in an **ORIX.FAN**.



● Refer to page C-99 for further detail.

MRS Series

High-Efficiency, Low-Noise Models

200mm-90mm



Materials

Frame : Die Cast Aluminum
 Blades : Resin
 Flammability Grade: V-0

Specifications

Model		Voltage V	Frequency Hz	Current A	Input Power W	Speed r/min	Max. Air Flow m ³ /min (m ³ /h)	Max. Static Pressure Pa	Noise Level dB (A)	Capacitor μ F
Electronic Alarm Type	Standard Type									
MRS20-EM	MRS20-E	Single-Phase230	50	0.4	75	2850	13.2(792)	221	56	6.0
		Single-Phase230	60	0.5	95	3400	15.5(930)	226	60	
	Single-Phase100	50	0.8	75	2850	13.2(792)	221	56		
MRS20-BM	MRS20-BUL	Single-Phase100	60	1.0	95	3350	15.5(930)	186	60	6.0
		Single-Phase115	60	1.0	95	3400	15.5(930)	186	61	

- Values for maximum air flow and maximum static pressure are measured by the double-chamber method.
- Noise level is measured in the A range, at a distance of 1m from the fan intake side.
- A thermal protector is installed. If the fan heats up, the thermal protector goes into operation and the fan stops. Once the fan temperature drops, it will automatically restart. Perform inspection work after turning off the power source.
- Fans bearing the CE mark should only be used with Class I equipment. When installing into the equipment, either earth the fan or ensure that there is no contact with bare hands. For protection, use the optional finger guard. Standards specifications are listed on page D-2.

Alarm Specifications

Alarm Activation Speed 1800±300r/min

When fan a speed drops below 1800±300r/min, the alarm output signal is output continuously at H level.

Since alarm circuits do not have delay functions, an external delay circuit is required to prevent speed detection when starting the fan or at other times when fan speed is below the alarm activation speed. The delay time should be at least 10 seconds.

Alarm Circuit

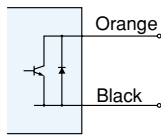

Orange Alarm Output(Open Collector)
 H (Tr=OFF):Abnormal Operation
 L (Tr=ON) :Normal Operation
 Black GND
 Maximum voltage:Vout =30V DC max.
 Maximum current:Iout =15mA max.

Air Flow – Static Pressure Characteristics

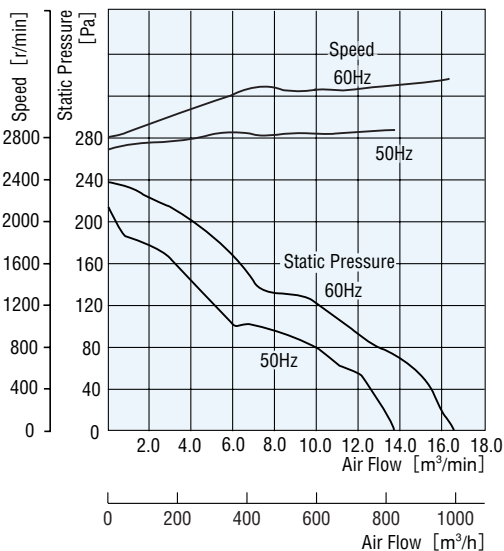

Audible Noise Frequency Analysis

Measured at a distance of 1m from the fan intake side

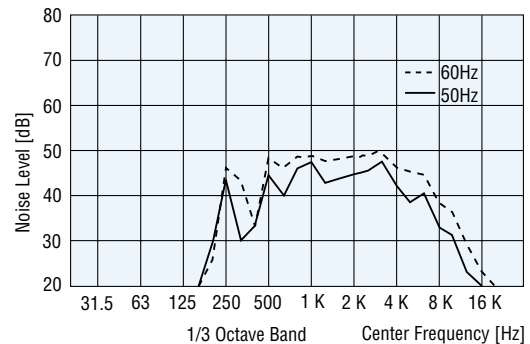

Dimensions (Scale 1/4, Unit=mm)

● Mass: 2.5kg

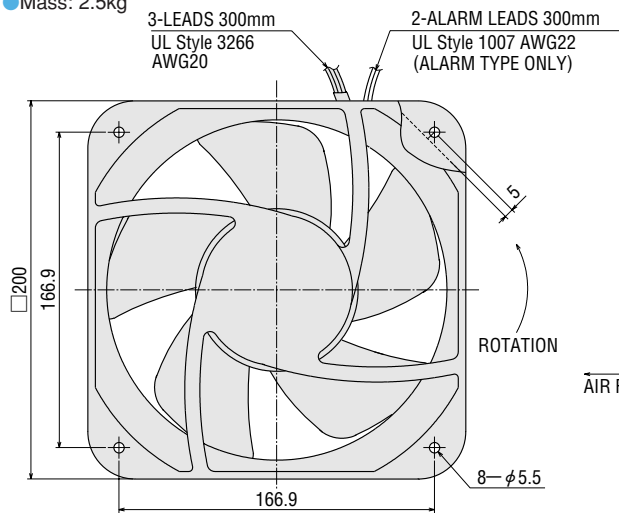

● Capacitor

CH60BFAUL for **MRS20-E,-EM** Mass: 85g

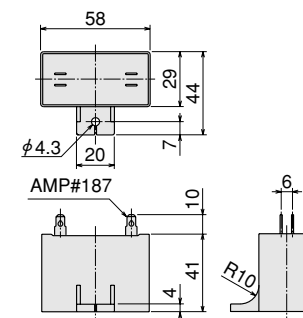

CH60UL for **MRS20-BUL,-BM** Mass: 32g

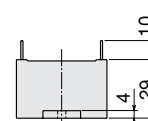
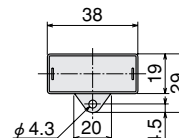

Panel Cut-Out (Scale 1/4, Unit: mm)

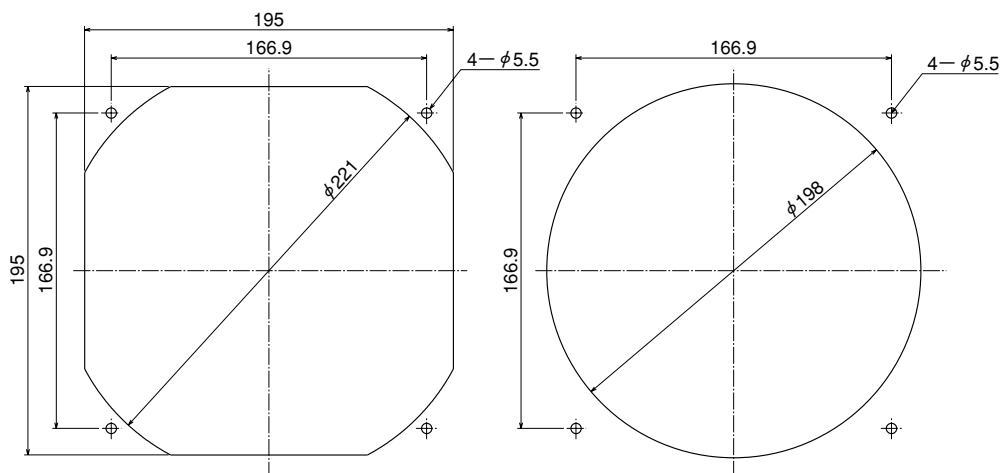

Outlet side

Intake side

Wiring Diagrams

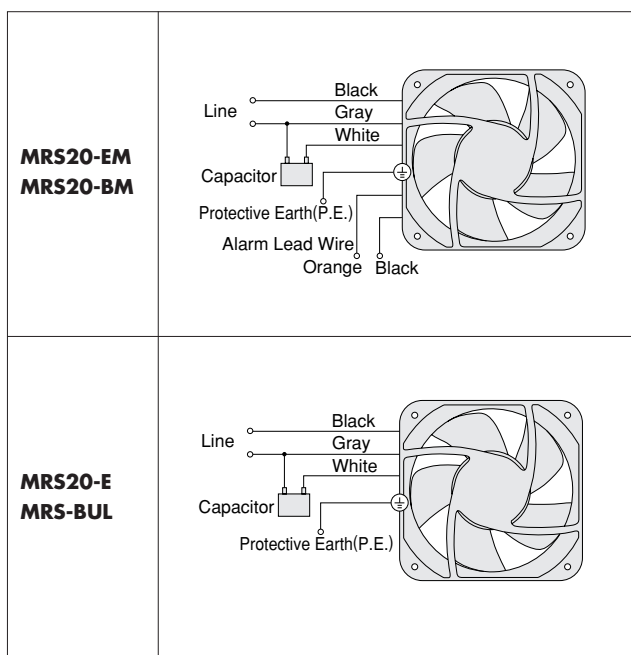

Accessories (Sold Separately)

Item	Model	Safety Standards	Page
Finger Guard	FG20D	*	C-99

* These products have been designed to pass tests set forth under the UL and CSA standards for equipment used in fans. They conform to the standards only when used in an **ORIX.FAN**.



Finger Guard

● Refer to page C-99 for further detail.

MRS Series

High-Efficiency, Low-Noise Models

180mm-90mm



Materials

Frame : Die Cast Aluminum
 Blades : Resin
 Flammability Grade: V-0

Specifications

Model		Voltage V	Frequency Hz	Current A	Input Power W	Speed r/min	Max. Air Flow m ³ /min (m ³ /h)	Max. Static Pressure Pa	Noise Level dB (A)	Capacitor μ F
Electronic Alarm Type	Standard Type									
MRS18-ETM	MRS18-E	Single-Phase230	50	0.4	75	2850	11.0(660)	196	56	6.0
		Single-Phase230	60	0.5	95	3350	12.5(750)	245	60	
		Single-Phase100	50	0.8	75	2850	11.0(660)	196	56	
MRS18-BTM	MRS18-BUL	Single-Phase100	60	1.0	95	3300	12.8(768)	245	60	6.0
		Single-Phase115	60	1.0	95	3350	12.8(768)	245	61	

- Values for maximum air flow and maximum static pressure are measured by the double-chamber method.
- Noise level is measured in the A range, at a distance of 1m from the fan intake side.
- A thermal protector is installed. If the fan heats up, the thermal protector goes into operation and the fan stops. Once the fan temperature drops, it will automatically restart. Perform inspection work after turning off the power source.
- Fans bearing the CE mark should only be used with Class I equipment. When installing into the equipment, either earth the fan or ensure that there is no contact with bare hands. For protection, use the optional finger guard. Standards specifications are listed on page D-2.

Alarm Specifications

Alarm Activation Speed 1800±300r/min

When fan a speed drops drop below 1800±300r/min, the alarm output signal is output continuously at H level.

Since alarm circuits do not have delay functions, an external delay circuit is required to prevent speed detection when starting the fan or at other times when fan speed is below the alarm activation speed. The delay time should be at least 10 seconds.

Alarm Circuit

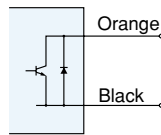

Orange Alarm Output(Open Collector)
 H (Tr=OFF):Abnormal Operation
 L (Tr=ON) :Normal Operation
 Black GND
 Maximum voltage:Vout =30V DC max.
 Maximum current:Iout =15mA max.

Air Flow – Static Pressure Characteristics

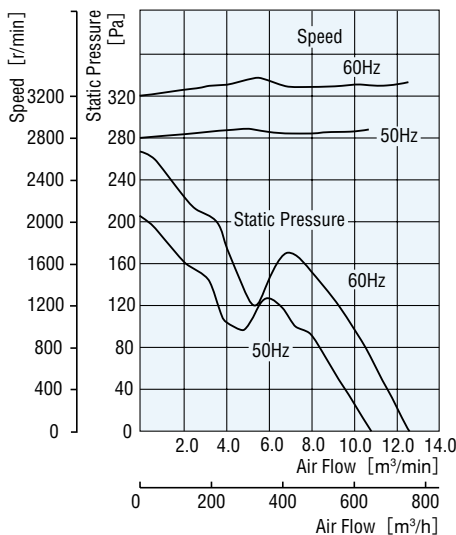

Audible Noise Frequency Analysis

Measured at a distance of 1m from the fan intake side

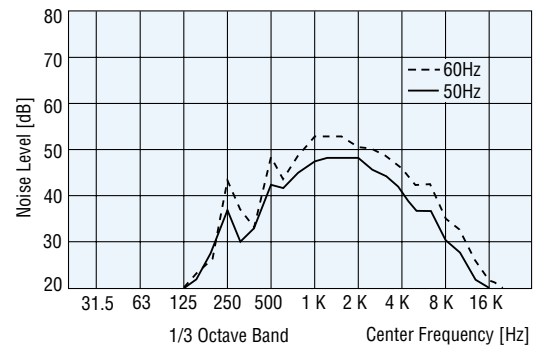

■ Dimensions (Scale 1/4, Unit=mm)

● Mass: 2.5kg

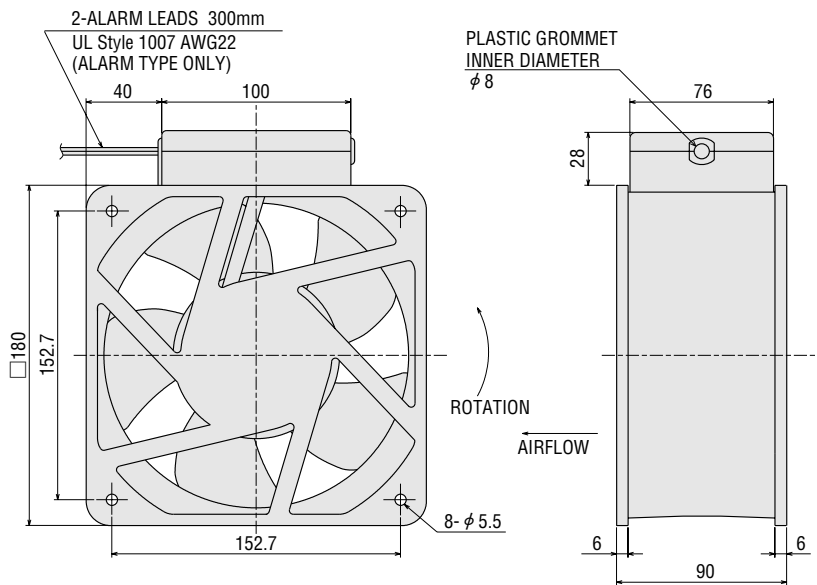

● Capacitor (Single-Phase standard types of fans contain a built-in capacitor.)

CH60BFAUL for **MRS18-ETM** Mass: 85g

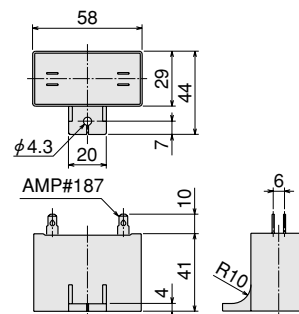

CH60UL for **MRS18-BTM** Mass: 32g

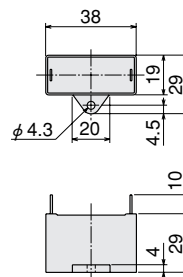

■ Panel Cut-Out (Scale 1/4, Unit=mm)

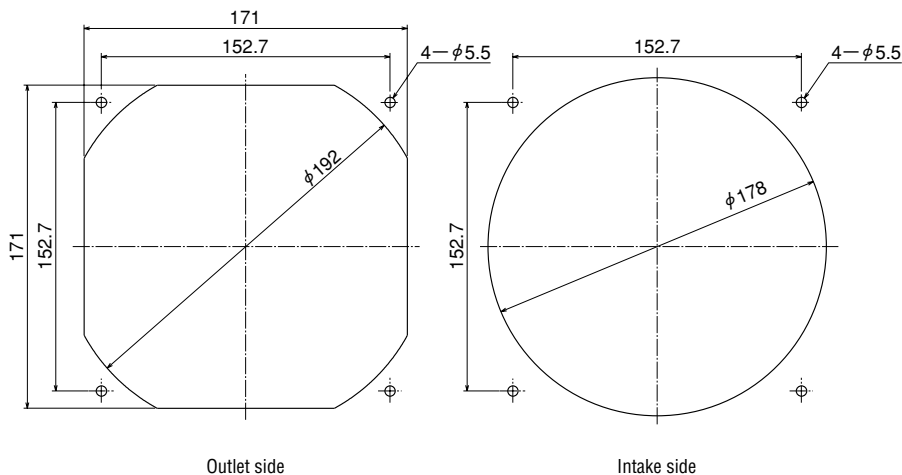

■ Wiring Diagrams

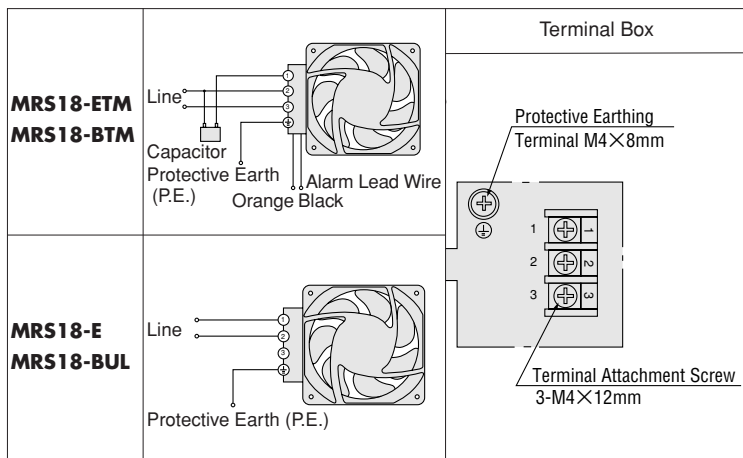

■ Accessories (Sold Separately)

Item	Model	Safety Standards	Page
Finger Guard	FG18D	*	C-98
Filter	FL18	—	C-101

* These products have been designed to pass tests set forth under the UL and CSA standards for equipment used in fans. They conform to the standards only when used in an **ORIX.FAN**.

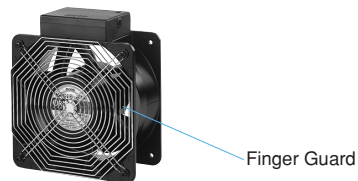

● A filter can be installed in place of the finger guard.

MRS Series

High-Efficiency, Low-Noise Models

160mm-62mm



Materials

Frame : Die Cast Aluminum
 Blades : Resin
 Flammability Grade: V-0

Specifications

Model		Voltage V	Frequency Hz	Current A	Input Power W	Speed r/min	Max. Air Flow m ³ /min (m ³ /h)	Max. Static Pressure Pa	Noise Level dB (A)	Capacitor μ F
Electronic Alarm Type	Standard Type									
MRS16-ETM	MRS16-E	Single-Phase230	50	0.21	47	2800	6.2(372)	127	49	3.0
		Single-Phase230	60	0.21	45	3300	7.3(438)	157	54	
MRS16-BTM	MRS16-BUL	Single-Phase100	50	0.47	45	2800	6.2(372)	127	49	3.0
		Single-Phase115	60	0.49	55	3300	7.3(438)	157	53	

- Values for maximum air flow and maximum static pressure are measured by the double-chamber method.
- Noise level is measured in the A range, at a distance of 1m from the fan intake side.
- A thermal protector is installed. If the fan heats up, the thermal protector goes into operation and the fan stops. Once the fan temperature drops, it will automatically restart. Perform inspection work after turning off the power source.
- Fans bearing the CE mark should only be used with Class I equipment. When installing into the equipment, either earth the fan or ensure that there is no contact with bare hands. For protection, use the optional finger guard. Standards specifications are listed on page D-2.

Alarm Specifications

Alarm Activation Speed 1800±300r/min

When fan a speed drops below 1800±300r/min, the alarm output signal is output continuously at H level.

Since alarm circuits do not have delay functions, an external delay circuit is required to prevent speed detection when starting the fan or at other times when fan speed is below the alarm activation speed. The delay time should be at least 10 seconds.

Alarm Circuit

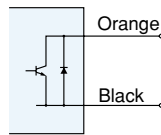

Orange Alarm Output(Open Collector)
 H (Tr=OFF):Abnormal Operation
 L (Tr=ON) :Normal Operation
 Black GND
 Maximum voltage:Vout =30V DC max.
 Maximum current:Iout =15mA max.

Air Flow – Static Pressure Characteristics

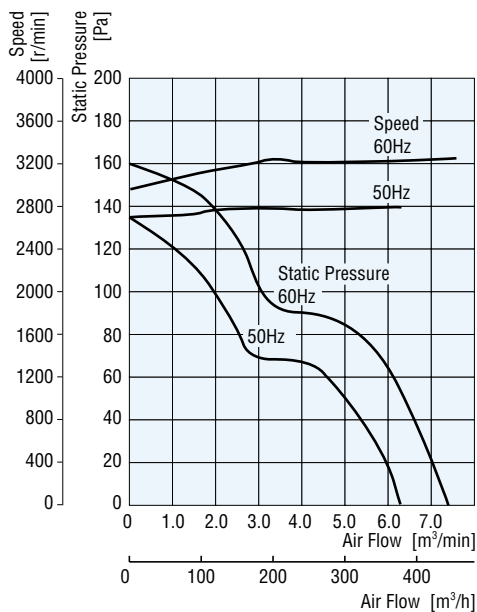

Audible Noise Frequency Analysis

Measured at a distance of 1m from the fan intake side

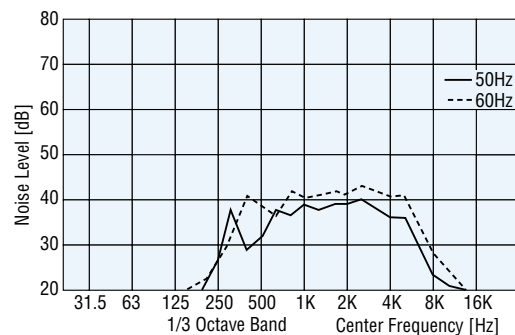

■ Dimensions (Scale 1/4, Unit=mm)

● Mass: 1.35kg

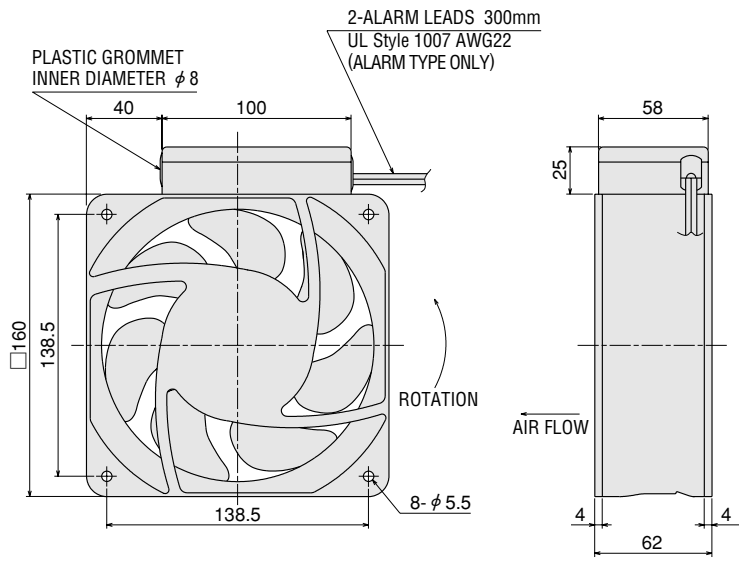

● Capacitor (Single-Phase standard types of fans contain a built-in capacitor.)

CH30FAUL2 for **MRS16-ETM** Mass: 22g

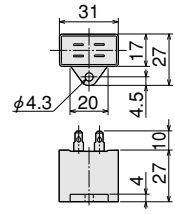

CH30UL for **MRS16-BTM** Mass: 23g

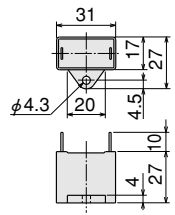

■ Panel Cut-Out (Scale 1/4, Unit=mm)

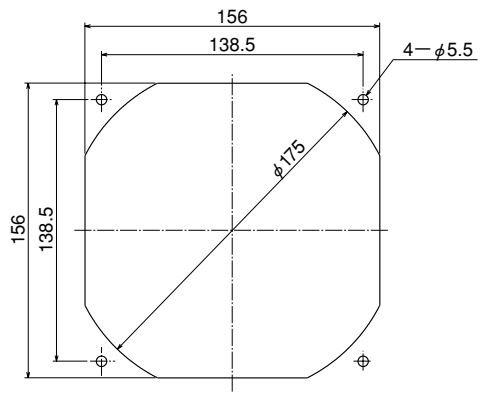

Outlet Side, Intake Side

■ Accessories (Sold Separately)

Item	Model	Safety Standards	Page
Finger Guard	FG16D	*	C-98
Filter	FL16	—	C-101

* These products have been designed to pass tests set forth under the UL and CSA standards for equipment used in fans. They conform to the standards only when used in an **ORIX.FAN**.

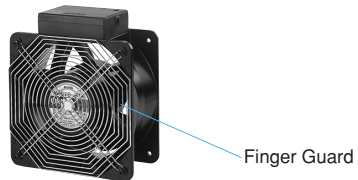

● A filter can be installed in place of the finger guard.

■ Wiring Diagrams

